

Vehicle Type	For Fire Fighting, Off-Road Vehicles
Gearbox Type	Vertical Medium Duty 4x4 Split Shaft Power Take-Off with Pump&Roll Feature

Product Code	UARA.804 4x4
Revision No- Date	01 / 16.02.2018

Products Views

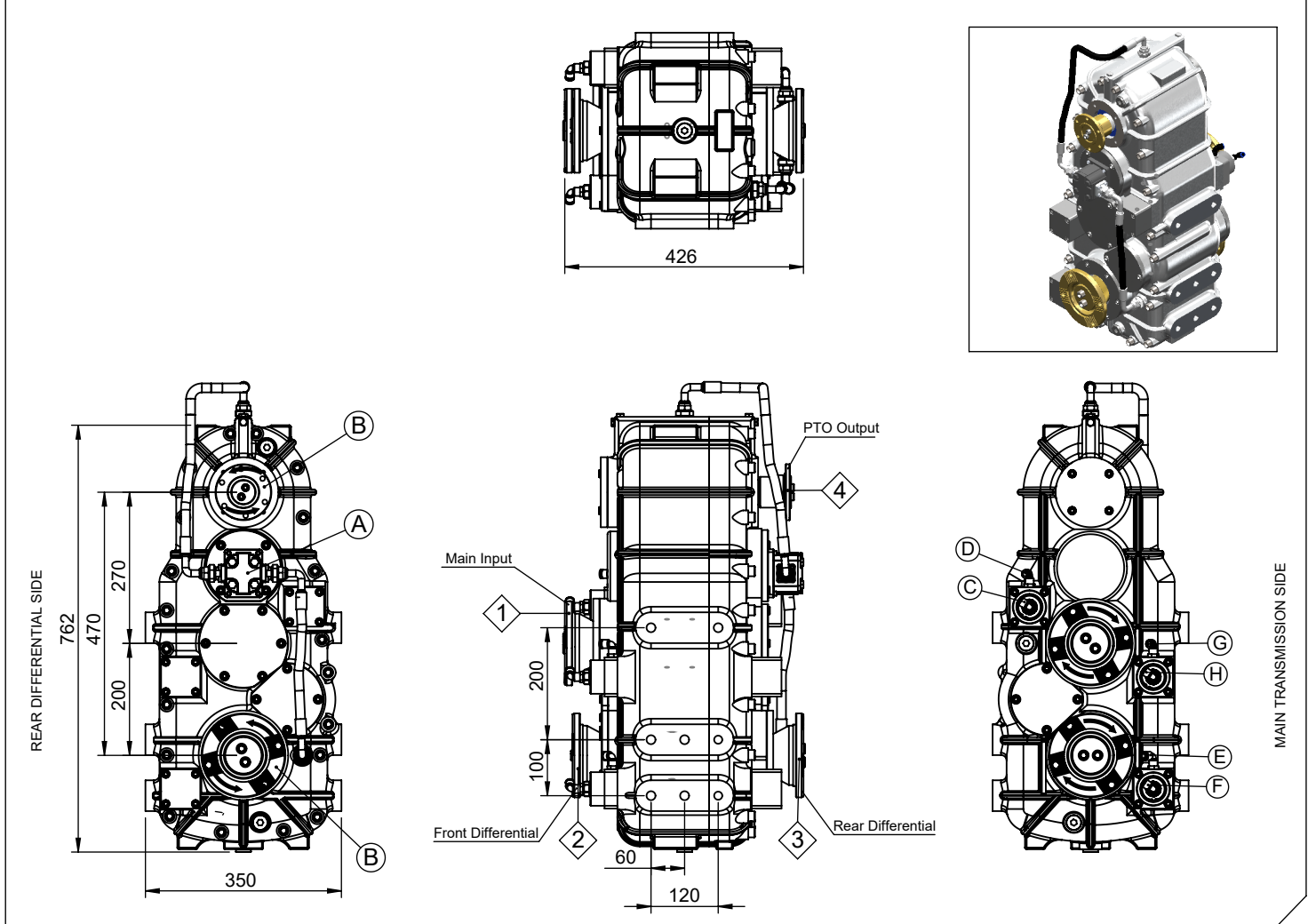

Component Details

- A : Lubrication Pump
- B : ISO 7646-7647 - SAE - DIN Flange
- C : Air Inlet: Main Drive Engaged
- D : Air Inlet: Main Drive Disengaged
- E : Air Inlet: Front Differential Engaged
- F : Air Inlet: Front Differential Disengaged
- G : Air Inlet: PTO Output Engaged
- H : Air Inlet: PTO Output Disengaged

Technical Details

Outputs	Max. Values	Working Speed Range	Input/Output	Mounting Type	Control Type
1	800 kgm	-	1/1	Split Shaft	Pneumatic
2 & 3	800 kgm	-	1/1	Weight	Sense of Rotation
4	135 kW	2500-3300 RPM	1/1.7		